

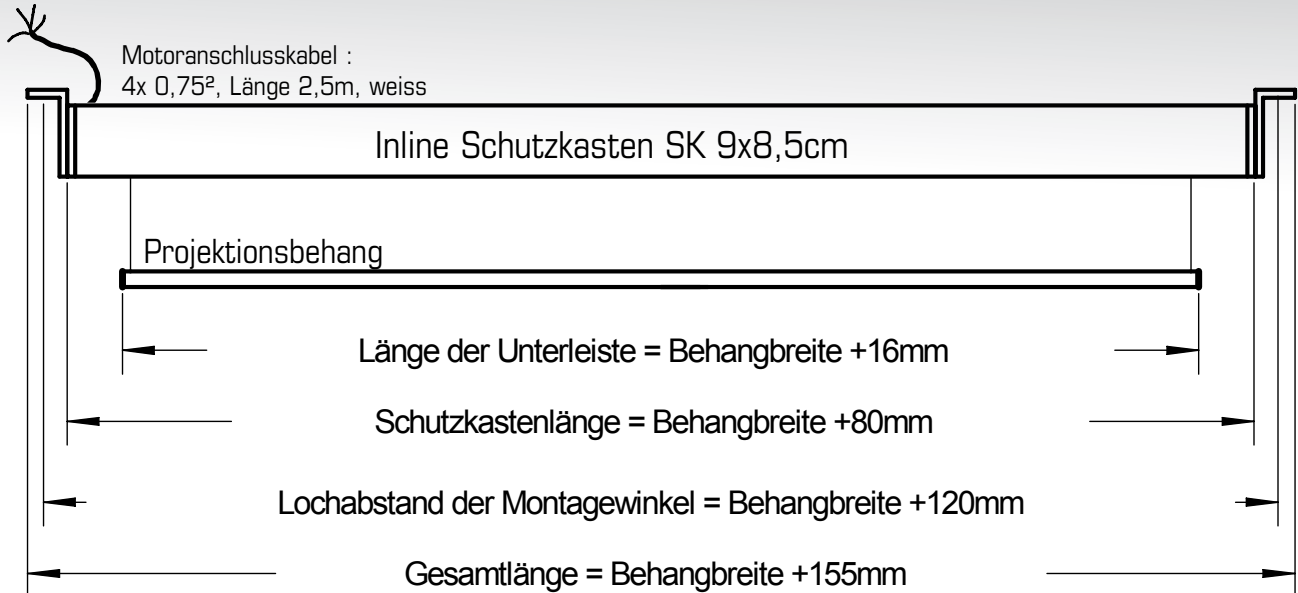

INLINE 90 MW MONTAGEWINKEL



Abmessungen der Projektionswand



Gesamtlänge: +/- 2mm

Querschnitt Inline-Schutzkasten

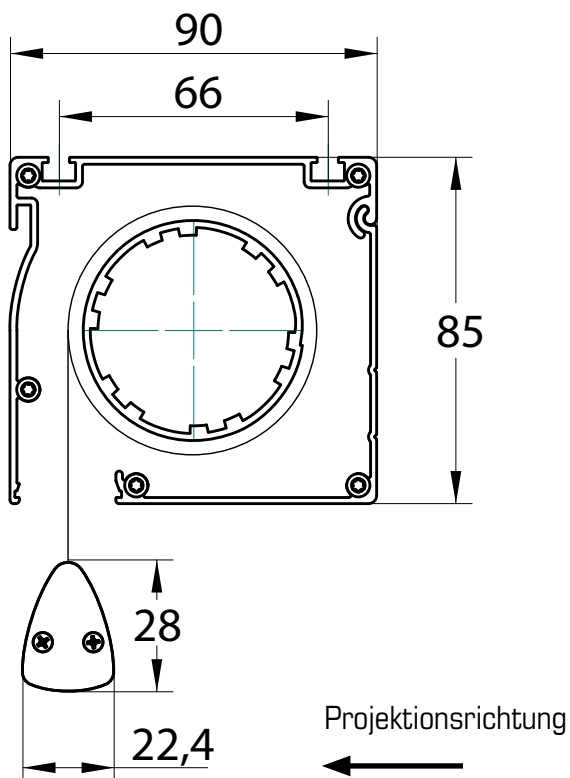

Universal Montagewinkel

für Wand und Deckenmontage

