

ELECTRIC SIT-STAND DESK

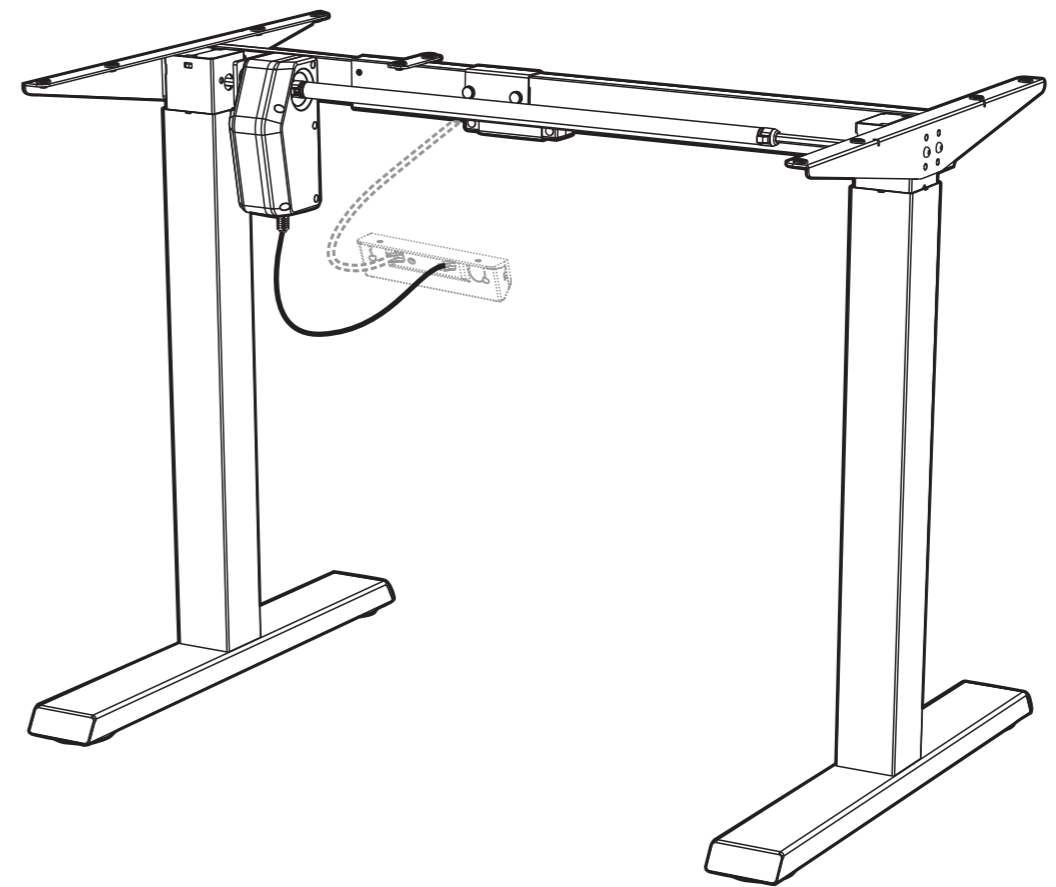

EN Read the entire instruction manual before you start installation and assembly. If you have any questions regarding any of the instructions or warnings, please contact your local distributor for assistance.

- CAUTION:** Use with products heavier than the rated weights indicated may result in instability causing possible injury.
 - Please closely follow the assembly instructions. Improper installation may result in damage or serious personal injury.
 - Safety gear and proper tools must be used. This product should only be installed by professionals.
 - This product is designed to be installed on solid concrete walls, masonry walls or wood stud walls.
 - Make sure that the supporting surface will safely support the combined weight of the equipment and all attached hardware and components.
 - Use the mounting screws provided and DO NOT OVER TIGHTEN mounting screws.
 - This product contains small items that could be a choking hazard if swallowed. Keep these items away from children.
 - This product is intended for indoor use only. Using this product outdoors could lead to product failure and personal injury.
- IMPORTANT:** Ensure that you have received all parts according to the component checklist prior to installation. If any parts are missing or faulty, contact your place of purchase for a replacement.
- MAINTENANCE:** Check that the product is secure and safe to use at regular intervals (at least every three months).

DE Bitte vor Beginn der Montage und Zusammenbau das ganze Handbuch durchlesen. Bitte sich mit dem Händler vor Ort bei Fragen zur Anleitung oder Warnungen in Verbindung setzen.

- VORSICHT:** Bei Verwendung mit Produkten, die das zulässige Gewicht überschreiten, können Schäden oder möglicherweise Verletzungen die Folge sein.
 - Halterungen sollen entsprechend den Montageanweisungen angebracht werden. Eine unsachgemäße Montage kann Schäden oder Verletzungen zur Folge haben.
 - Sicherheitsausrüstung und geeignete Werkzeuge verwenden. Die Montage des Produktes sollte nur von Fachleuten durchgeführt werden.
 - Dieses Produkt kann auf Wänden mit Fachwerk, massiven Beton- oder Steinwänden montiert werden.
 - Die tragenden Oberflächen sollten das gesamte Gewicht von Geräten und allen zusätzlichen Bauteilen sicher aushalten können.
 - Nur die mitgelieferten Einbauschrauben verwenden und die Schrauben NICHT ZU FEST ANZIEHEN.
 - Dieses Produkt enthält Kleinteile, die Erstickungsgefahr beim Verschlucken hervorrufen können. Diese Teile von Kindern fernhalten.
 - Dieses Produkt nur in Innenräumen verwenden. Verwendung des Produktes im Außenbereich kann zu Verletzungen und Schäden führen.
- WICHTIG:** Vor der Montage bitte alle erhaltenen Bauteile mit der Bauteilliste abgleichen. Bei beschädigten oder fehlenden Teilen den Händler vor Ort nach Ersatzteilen fragen.
- WARTUNG:** Die Halterungsklammer regelmäßig auf Sicherheit und Stabilität prüfen (am besten alle drei Monate).

FR Lisez entièrement le guide d'utilisateur avant de commencer l'installation et le montage. Si vous avez des questions concernant les instructions ou les avertissements, veuillez contacter votre distributeur local pour une assistance.

- ATTENTION:** L'utilisation de produits plus lourds que les poids nominaux indiqués peut entraîner une instabilité causant des blessures potentielles.
 - Les supports doivent être joints comme spécifié dans les instructions de montage. Une mauvaise installation peut entraîner des dommages ou de graves blessures aux personnes.
 - Un équipement de sécurité et les outils appropriés doivent être utilisés. Ce produit devrait être installé uniquement par des professionnels.
 - Ce produit est conçu pour être installé sur des murs avec poteaux en bois, des murs en béton massif ou murs en brique.
 - Assurez-vous que la surface de soutien supporte en sécurité le poids combiné de l'équipement et de tous les matériaux et composants associés.
 - Utilisez les vis de montage fournies et NE SERREZ PAS TROP les vis de montage.
 - Ce produit contient de petites pièces qui peuvent causer un étouffement si elles sont avalées. Eloignez ces pièces des enfants.
 - Ce produit est prévu uniquement pour une utilisation à l'intérieur. L'utilisation de ce produit à l'extérieur peut entraîner une défaillance du produit ou des blessures aux personnes.
- IMPORTANT:** Avant l'installation, assurez-vous que vous avez reçu toutes les pièces selon la liste de vérification des composants. Si une pièce est manquante ou endommagée, téléphonez à votre distributeur local pour qu'il la remplace.
- MAINTENANCE:** A intervalles réguliers (au moins tous les trois mois) vérifiez que le support est d'utilisation sûre et fiable.

RU Перед началом установки и сборки прочитайте руководство по установке. Если у Вас возникли какие-либо вопросы относительно инструкций или предупреждений, свяжитесь с Вашим локальным распространителем для получения помощи.

- Внимание:** Использование продуктов, вес которых превышает указанный расчетный вес, может привести к нестабильности и возможным повреждениям.
 - Опоры должны быть установлены, как это показано в монтажных инструкциях. Неправильная установка может привести к получению серьезных травм.
 - Необходимо использовать предохранительное устройство и специальные инструменты. Продукт должен устанавливаться только профессионалами.
 - Продукт предназначен для установки на деревянные каркасные стены, твердые цементные стены или кирпичные стены.
 - Убедитесь, что несущая поверхность выдержит вес оборудования и всего установленного оборудования и комплектующих.
 - Необходимо использовать идущие в комплекте установочные шурупы и НЕ ПЕРЕТЯГИВАТЬ установочные шурупы.
 - Данный продукт содержит маленькие детали, которые представляют опасность удушья при проглатывании. Такие детали необходимо хранить в недоступном для детей месте.
 - Данный продукт предназначен только для эксплуатации в помещениях. Использование данного продукта на улице может привести к поломке продукта и получению травм.
- ВАЖНО:** Перед установкой убедитесь, что Вы получили все детали в соответствии со списком комплектующих. Если не хватает каких-либо деталей или они поломаны, свяжитесь с Вашим местным распространителем по вопросу замены.
- ТЕХНИЧЕСКОЕ ОБСЛУЖИВАНИЕ:** Необходимо регулярно проверять (как минимум, раз в три месяца), чтобы кронштейн был зафиксирован, и его использование было безопасным.

ES Lea todo el manual de instrucciones antes de comenzar la instalación y ensamble de la unidad. Si tiene alguna inquietud con respecto a las instrucciones o advertencias, comuníquese con su distribuidor local.

- PRECAUCIÓN:** utilizar con productos de mayor peso al indicado en los límites de peso podría ocasionar inestabilidad y posibles heridas personales.
 - Los soportes deben acoplarse tal como se indica en las instrucciones de ensamble. Una incorrecta instalación podría ocasionar daños y serias heridas personales.
 - Utilice las herramientas y equipo de seguridad adecuados. Este producto solo debe ser instalado por profesionales.
 - Este producto está diseñado para instalaciones en paredes de madera sólida, concreto sólido o bloques.
 - Asegúrese de que la superficie de fijación sostenga de manera segura el peso total del equipo y todos sus componentes y hardware.
 - Utilice los tornillos de ensamble suministrados y NO aplique demasiada tensión a los tornillos.
 - Este producto contiene piezas pequeñas que representan un riesgo de asfixia. Mantenga estas piezas fuera del alcance de los niños.
 - Este producto está diseñado para uso en interiores solamente. Utilizar este producto en exteriores podría ocasionar fallas y heridas personales.
- IMPORTANTE:** Asegúrese de que haya recibido todas las piezas según la lista de verificación de componentes para la instalación. Si falta alguna de las partes, o está dañada, comuníquese con su distribuidor.
- MANTENIMIENTO:** Compruebe periódicamente que el soporte esté asegurado y listo para usar (al menos cada tres meses).

PT Leia todo o manual de instruções antes de iniciar a instalação e montagem. Se você tiver alguma dúvida sobre quaisquer uma das instruções ou avisos, por favor, entre em contato com o seu distribuidor local para assistência.

- ATENÇÃO:** O uso com produtos mais pesados do que os pesos indicados pode resultar em instabilidade, causando possíveis danos.
 - Os suportes devem ser anexados como especificado nas instruções de montagem. A instalação incorreta pode causar danos ou sérias lesões pessoais.
 - Equipamentos de segurança e ferramentas adequadas devem ser utilizadas. Este produto só deve ser instalado por profissionais.
 - Este produto é projetado para ser instalado em pilares verticais de paredes de madeira, paredes de concreto sólido ou de tijolos.
 - Certifique-se que a superfície de suporte suportará com segurança o peso combinado do equipamento e todas as ferragens e componentes anexados.
 - Use os parafusos de montagem fornecidos e NÃO APERTE EXCESSIVAMENTE os mesmos.
 - Este produto contém pequenas peças que podem causar asfixia se ingeridas. Mantenha esses itens longe do alcance de crianças.
 - Este produto destina-se somente para uso interno. Usá-lo em ambiente externo pode causar falhas no produto e lesões pessoais.
- IMPORTANTE:** Assegure-se que você recebeu todas as peças, de acordo com a lista de componentes, antes da instalação. Se alguma peça estiver faltando ou é defeituosa, contate o seu distribuidor local para substituição.
- MANUTENÇÃO:** Certifique-se que o suporte seja seguro e protegido para o uso em intervalos regulares (pelo menos a cada três meses).

AR الرجاء قراءة دليل الإرشادات بالكامل قبل البدء في التركيب والتجميع. إذا كانت توجد لديك أي استفسارات بشأن أي من الإرشادات أو التحذيرات، فالرجاء الاتصال بالموزع المحلي لديك لمطلب المساعدة.

- تحذير: قد يؤدي استخدام هذا المنتج مع منتجات ذات أوزان أكبر من الأوزان المقررة المشار إليها إلى حدوث اختلال قد ينجم عنه التعرض لإصابة.
 - يجب ربط الحوامل كما هو موضح في إرشادات التجميع. قد يؤدي تركيب الحامل بشكل غير صحيح إلى حدوث تلف أو التعرض لإصابة شخصية خطيرة.
 - يجب استخدام معدات السلامة والأدوات المناسبة. يجب تركيب هذا المنتج فقط بمعرفة أشخاص مختصين.
 - لقد تم تصميم هذا المنتج لتركيبه على جدران تحتوي على عروق خشبية، أو جدران من الخرسانة الصلبة، أو جدران طوبية.
 - تأكد من أن السطح الداعم سيقبل كل أوزان المعدات علاوة على وزن الأجهزة والمكونات الملحقة بها.
 - استخدم مسامير التركيب المولبية المرفقة ولا تفرط في إحكام ربطها.
 - يحتوي هذا المنتج على عناصر صغيرة قد يؤدي ابتلاعها إلى الإصابة بالاختناق. أحفظ هذه العناصر بعيداً.
 - هذا المنتج مخصص للاستخدام المنزلي فقط. قد يؤدي استخدام هذا المنتج خارج المنزل إلى تعطله أو حدوث إصابة شخصية.
- هام:** تأكد من أن جميع المكونات التي تحتوي عليها قائمة المكونات مرفقة مع المنتج قبل البدء في التركيب. إذا كانت توجد هناك أي مكونات مفقودة أو معيبة، فالرجاء الاتصال هاتفياً بالموزع المحلي لديك للحصول على بديل لها.
- الصيانة:** يتحقق أن السناد محكم وأمن لاستخدامه على فترات منتظمة (على الأقل كل ثلاثة شهور).

JA 設置や組立てを始める前に、すべての取扱説明書をご一読ください。取扱説明書または警告に関してご不明な点がございましたら、お住まいの地域の代理店までお問い合わせください。

- 注意:** 定格可搬より重い製品の使用は、不安定な状態になり傷害を引き起こす恐れがあります。
 - マウントは組立の取扱説明書の指示に従って取り付けてください。不適切な取り付けにより、損傷や重大な身体傷害を引き起こす恐れがあります。
 - 安全装置および適切な道具をご使用ください。本製品は専門の知識を有する人が設置を行ってください。
 - 本製品は、木製スタッド壁、硬いコンクリート壁、またはレンガ壁に設置するように設計されています。
 - 支持面が設備およびすべての付属のハードウェアの総重量とコンポーネントを安全に支えるようにしてください。
 - 提供された取り付けネジを使用し、ネジを決して締めすぎないようにしてください。
 - 本製品には飲み込んだら窒息する危険性のあ地小型製品が含まれています。小さなお子様手の届かない場所に保管してください。
 - 本製品は屋内使用のみを目的としています。本製品を屋外で使用すると、製品の不具合や身体傷害を導く恐れがあります。
- 重要:** 設置に先立って、構成要素のチェックリストに従い全ての部品がお手元にあるかご確認ください。
- 部品が見当たらない場合や欠陥品の場合は、交換のにあたり、お住まいの地域の代理店までお電話でご連絡ください。
- 保守管理:** プラケットは安全に使用するため、定期的(少なくとも3ヵ月毎に)チェックしてください。

PM-DESK-00

PM-DESK-01

PureLink GmbH
 Von-Liebig-Str. 10 | 48432 Rheine | Germany
 Phone: +49 (0) 5971 800 299 0

PureLink GmbH hereby declares that this product complies with Directive 1907/2006/EU and 2011/65/EU.

I Preface





This electric height adjustable standing desk consists of a heavy-duty steel desk frame and a motorized height adjustment system. Please read and completely understand this manual before installation in order to make sure the safe and correct use of the system and maintain the longevity of the overall construction and the built-in electronics.

Instructions of Safety and Warnings:

- Any failure to comply with the safety and installation instructions in this manual may cause serious bodily injury.
- Any incomplete observation of the instructions, warnings and additional information marked with the "Note" and "⚠" may result in serious damage to the system or its components.
- This product can be used by children aged from 8 years and above if they have been given supervision or instruction concerning use of the appliance in a safe way and understand the hazards involved. Children shall not play with the appliance. Cleaning and user maintenance shall not be made by children without supervision. Unplug the desk when the system isn't in use, and place the power plug out of children reach.
- Persons with reduced physical, mental abilities and or lack of experience and knowledge must not use the product, unless they're under supervision, understand the hazards involved or they have been thoroughly instructed in the use of the apparatus by a person who is responsible for the safety of these persons.
- Users should make sure that they never sit on the desktop in order to prevent serious bodily injury.

⚠ CAUTION Electrical Safety Instructions:

The product is powered by electricity. In order to avoid burns, fire and electric shock, please read the instructions carefully.

-  Don't clean the product with water while the power is still connected.
-  Never operate the system if it's in moist environment or its electrical components have contact with liquids.
-  Don't disassemble or replace components while the power is still connected.
-  Don't operate the system if the control box makes noise or odor. Alterations of the given power unit and control box aren't allowed.
-  Never operate the system with a damaged cord or plug. Please contact your point of purchase to replace the damaged parts.

⚠ CAUTION Other Safety Instructions:

- Clear up all obstacles within the height adjustment range.
- Don't leave the cords or plug unorganized in order to prevent tripping hazards.
- Any attempts to reconstruct the desk frame aren't allowed.
- Don't add anything to the adjustable junctions of the desk frame.
- Outdoor use is prohibited.

I Preparation

1 What are the specifications you need to know?

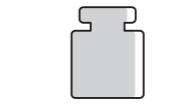

Weight Capacity
80kg (176lbs)



Power Input
(100~240V)



Operation Temperature
(-5°C~+40°C)

2 What are the tools you require while installation?



Bubble Level



Allen Wrench
(Included)



Drill



Phillips Screwdriver

3 What's the thing you'd better have before installation?

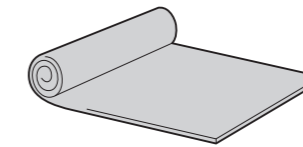

A Shipping Blanket
to protect the desk
and the floor





4 Things you need to know before installation

Please check all of the components shown in the component checklist. If any of the components are missing or damaged, contact your point of purchase for a replacement.



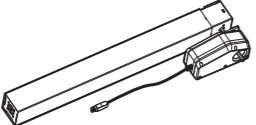
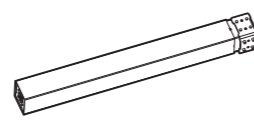
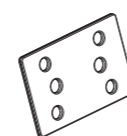
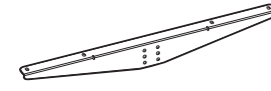

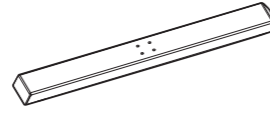
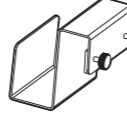
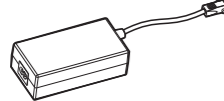

Disposal: The product with this mark indicates that this product shouldn't be disposed with other household wastes throughout the EU. To prevent possible harm to the environment or human health from uncontrolled waste disposal, recycle it responsibly to promote the sustainable reuse of material resources. To return your used device, please use the local recycle service or contact your point of purchase to withdraw the product.

I Checklist and Installation

 A (x1) Crossbar	 B (x1) Lifting Column	 C (x1) Lifting Column	 D (x1) Crossbar Spacer
 E (x2) Side Bracket	 F (x1) Sync Rod	 G (x2) Foot	 H (x1) Adapter Holder
 I (x1) AC Adapter	 J (x1) Power Plug	The picture of the controller is for your reference only. Actual product may vary.  K (x1) Controller	

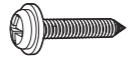
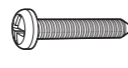
This page can be torn so that it's easier for you to match the components with the images.



 S-A (x16) Hex Head Screw	 S-B (x10) Phillips Head Screw+ 1 Spacer	 S-C (x2) Phillips Head Screw
 S-D (x3) Cable Clip	 S-E (x10) Anti-Vibration Pad	 S-F (x1) Allen Wrench

Now let's start the installation.

1. Assembling the Crossbar

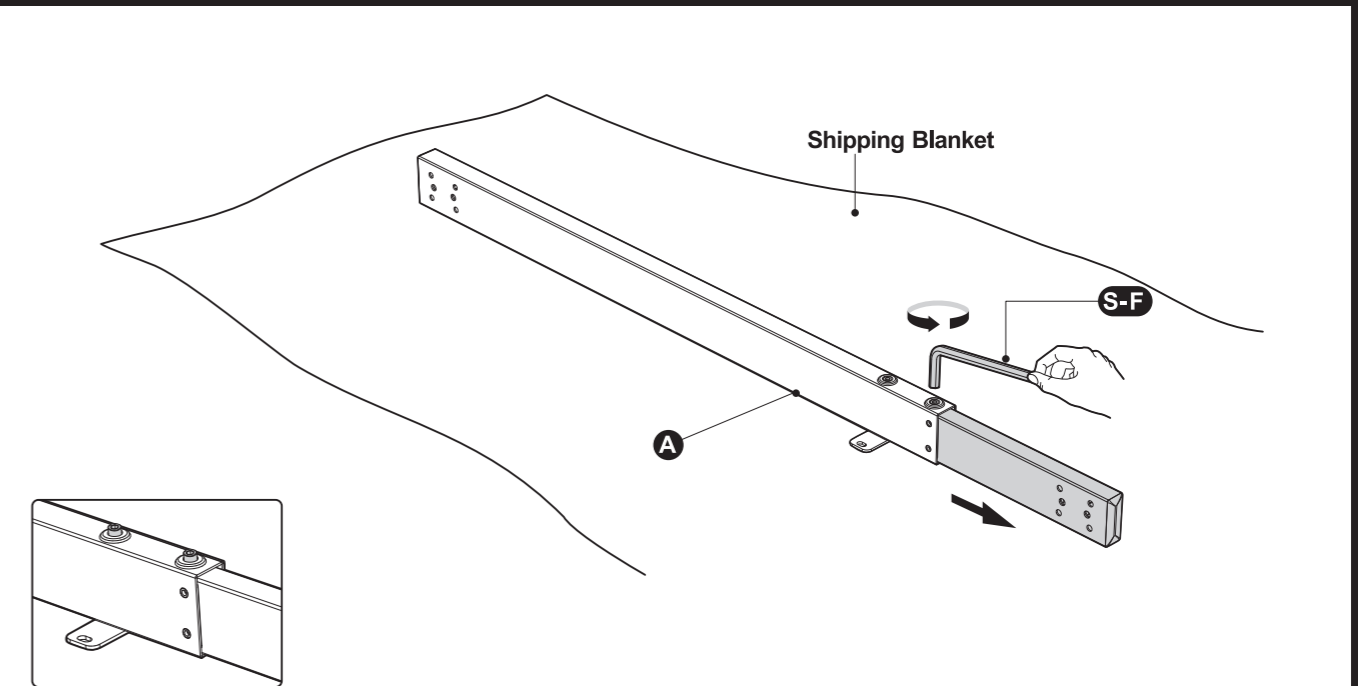

- Please prepare a spacious area for installation, and put a shipping blanket on the area to prevent scratches on the floor and the frame.
 - Loosen the hex head screws that fix the adjustable junction, but don't completely take out the screws.
- Note:** The drawing of the crossbar is the **backside** of it.

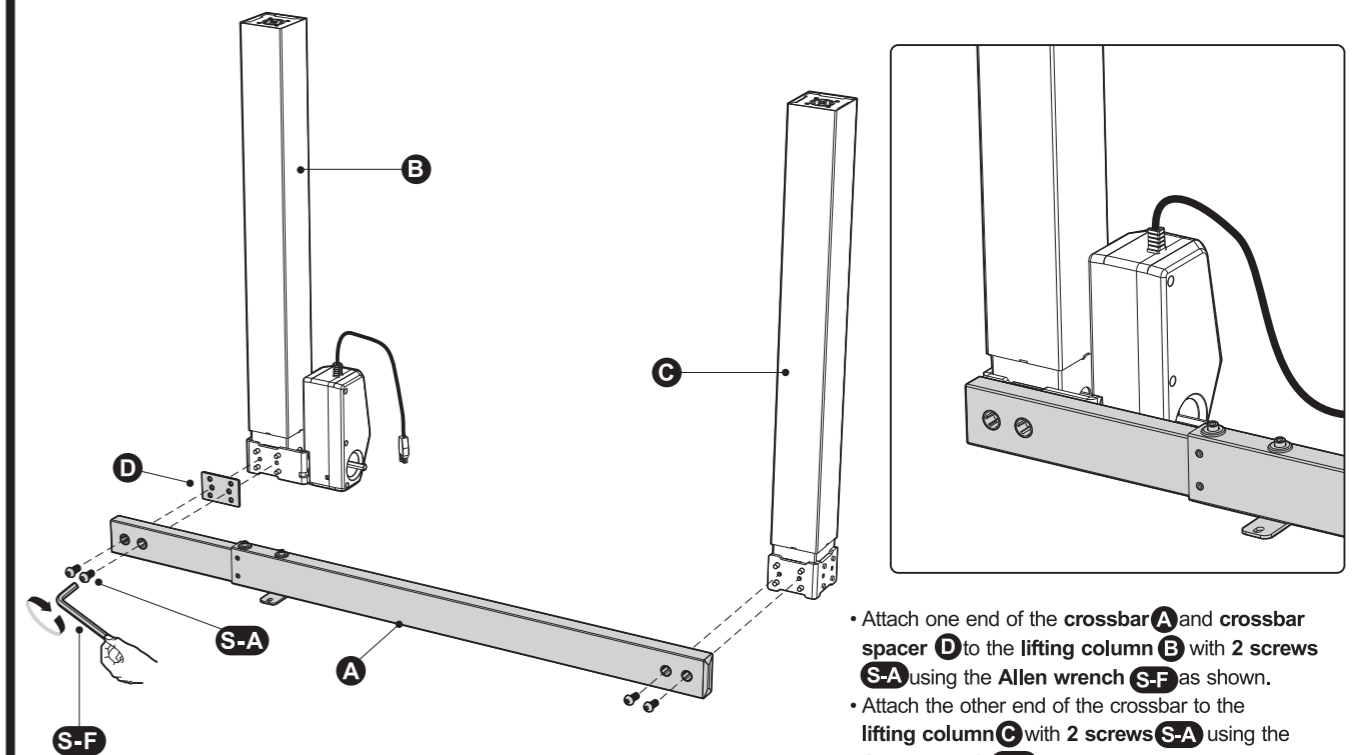

- Attach one end of the **crossbar A** and **crossbar spacer D** to the **lifting column B** with 2 screws **S-A** using the **Allen wrench S-F** as shown.
- Attach the other end of the crossbar to the **lifting column C** with 2 screws **S-A** using the **Allen wrench S-F**.

Note: Maintain the lifting columns in a **FACE DOWN** position during installation. This will aid in the remaining assembly steps.

2. Installing the Side Brackets

- Attach the **side bracket E** to the end of the lifting column with **2 screws S-A** using the **Allen wrench S-F** as shown.
- Repeat the same process to assemble the other side bracket.

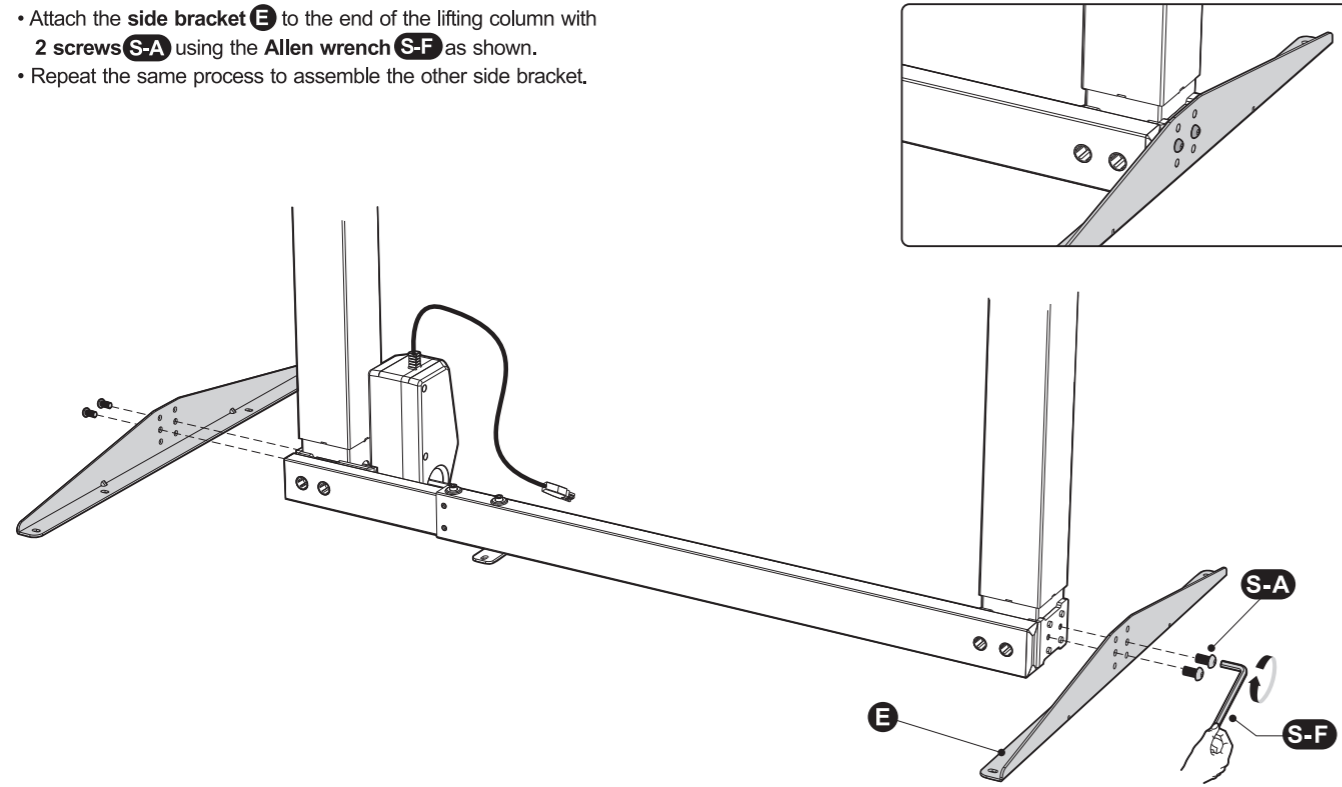

3. Assembling the Sync Rod

- Turn the right knob counterclockwise as shown to loosen the **sync rod F**.
- Attach the end of the sync rod as shown to the motor spindle in red line position and turn the right knob clockwise to tighten the connection.

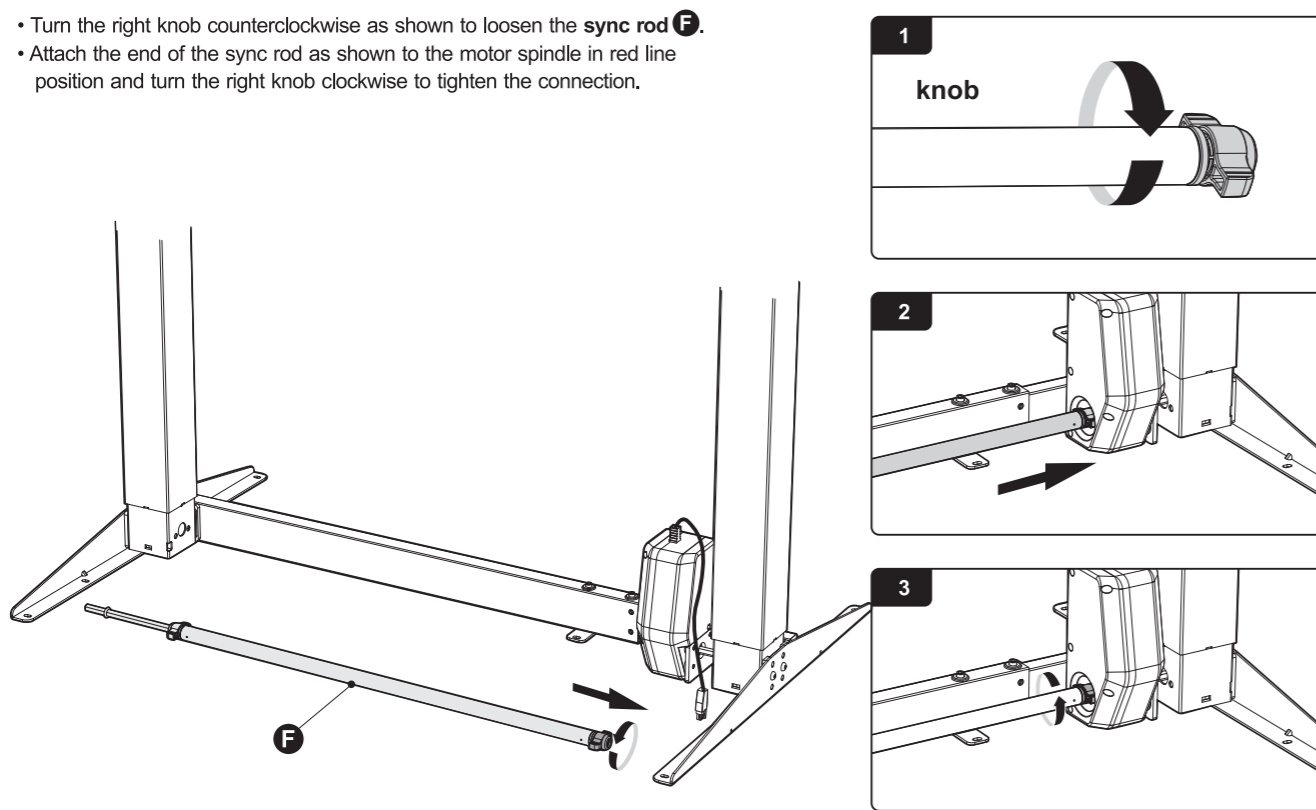

- Turn the left knob clockwise as shown to loosen the sync rod.
- Insert the other end of the sync rod into the column as shown.

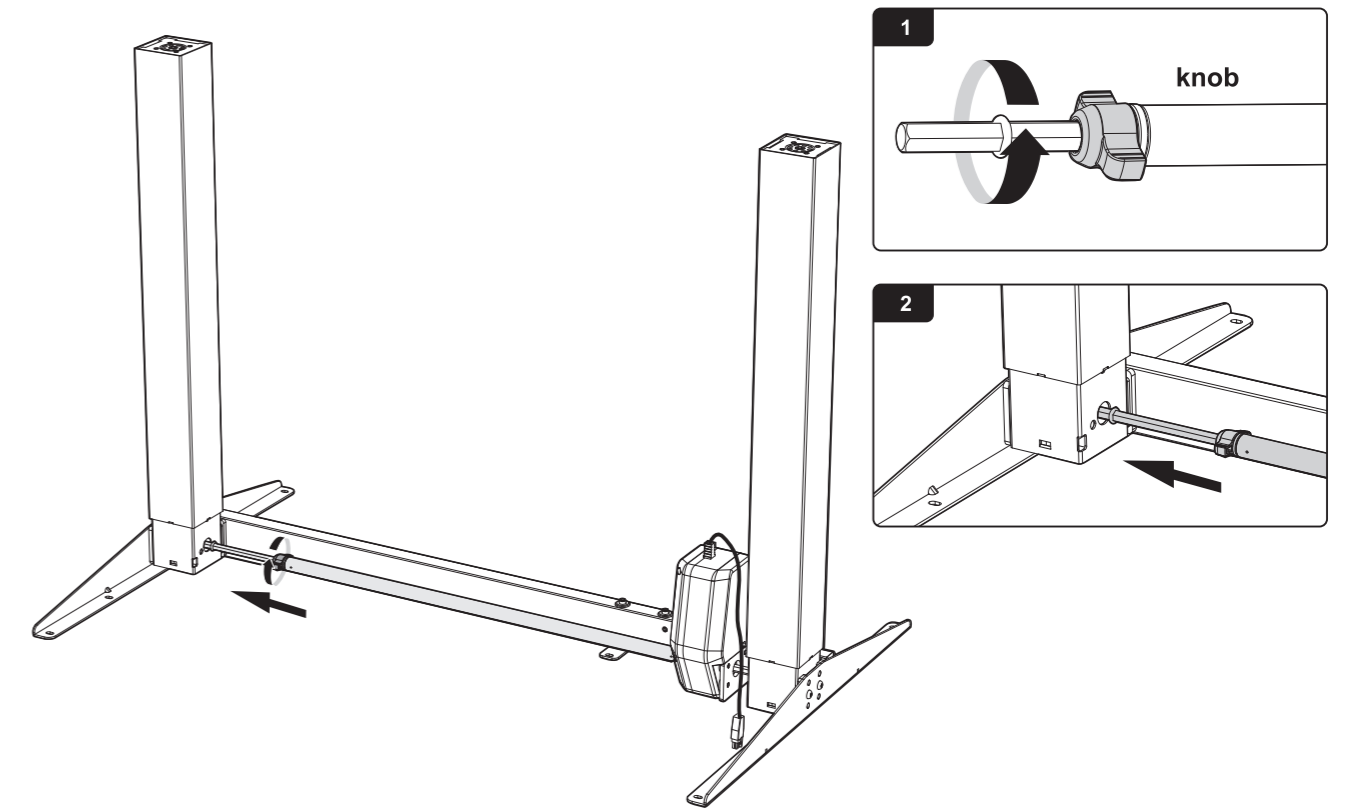

- Place the assembled frame on the back of the desktop as shown and then adjust the width of the crossbar to suit the size of the desktop.
 - Tighten all the hex head screws on the crossbar to finish the adjustment.
 - Re-tighten the sync rod by turning the knob counterclockwise as shown.
 - After tightening the screws, use a **drill** to make mounting holes on the backside of the desktop through the 10 mounting holes on the side brackets.
- Note:** The depth of the mounting holes should be over **10mm** and the diameter should be less than **3mm**.

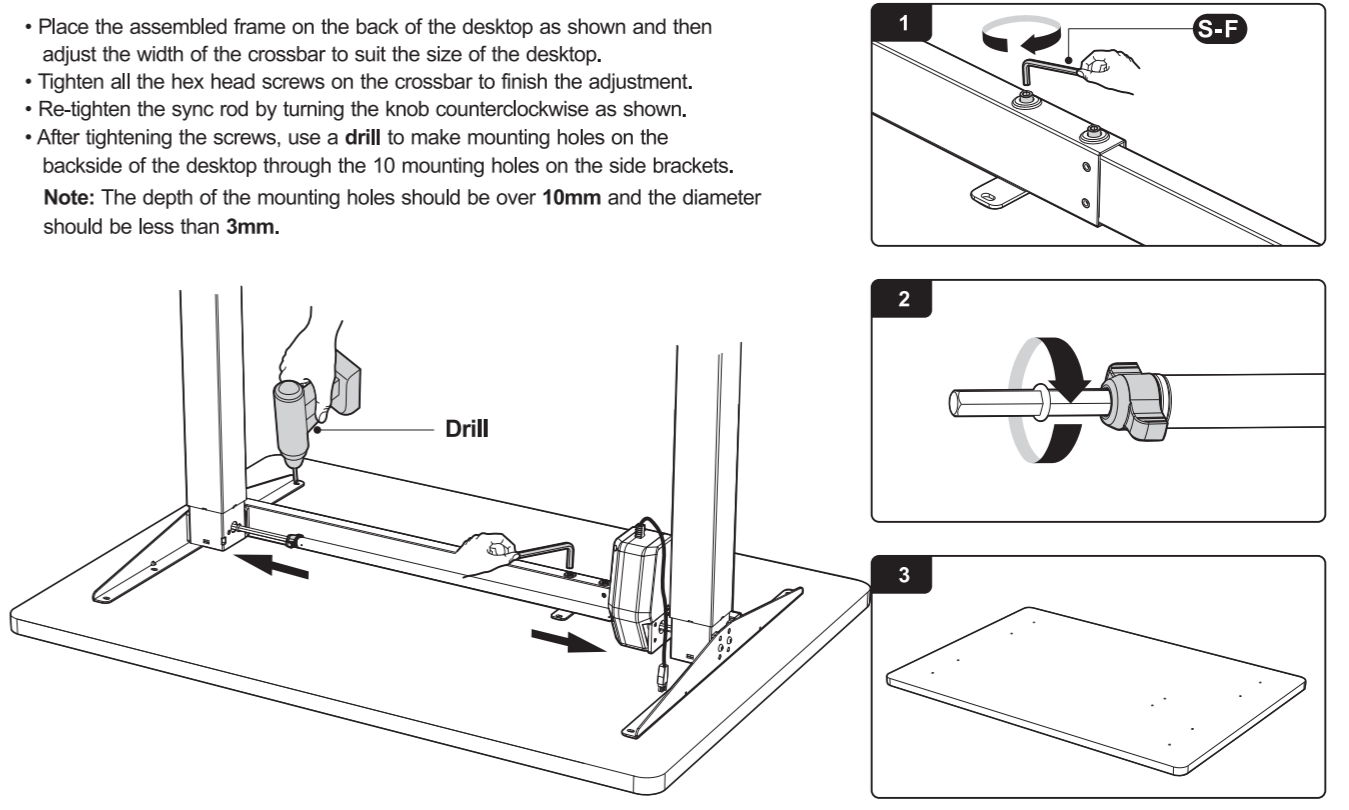

4. Installing the Feet

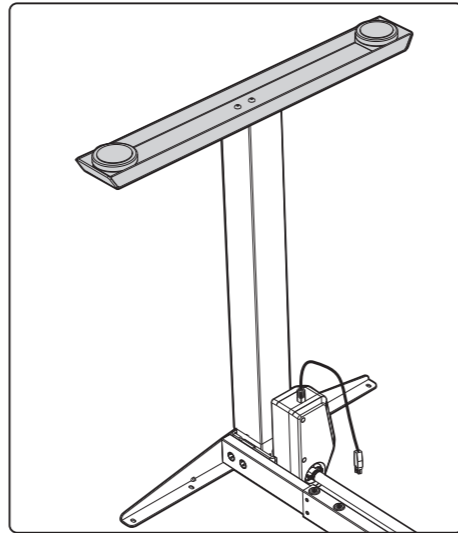
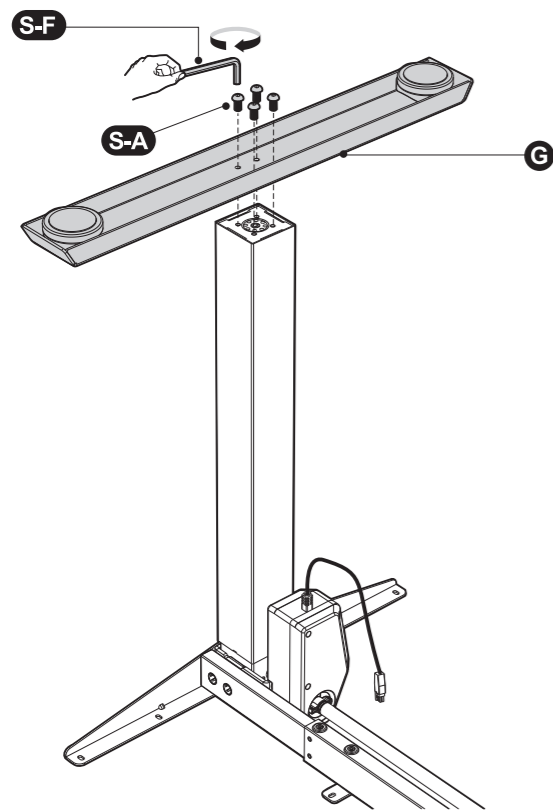

- Place the foot **G** on the bottom of the lifting column. Align the mounting holes on the foot with the screw holes on the lifting column.
- Fix the foot **G** with 4 screws **S-A** using the Allen wrench **S-F**.
- Repeat the same process to assemble the other foot.

5. Assembling the Adapter Holder

- Turn over the desk frame with the crossbar facing up.
- Hang the adapter holder **H** on the crossbar as shown.
- Tighten the knobs on the adapter holder and then put the AC adapter **I** into it.

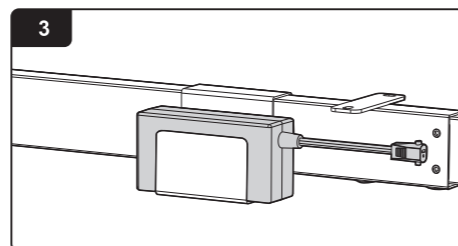
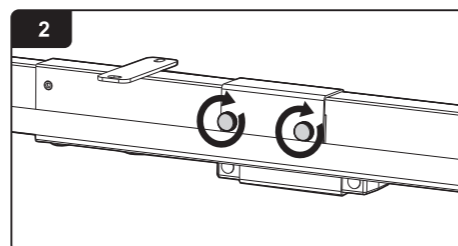
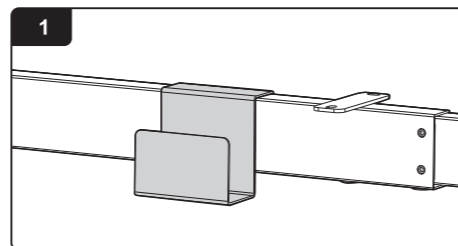
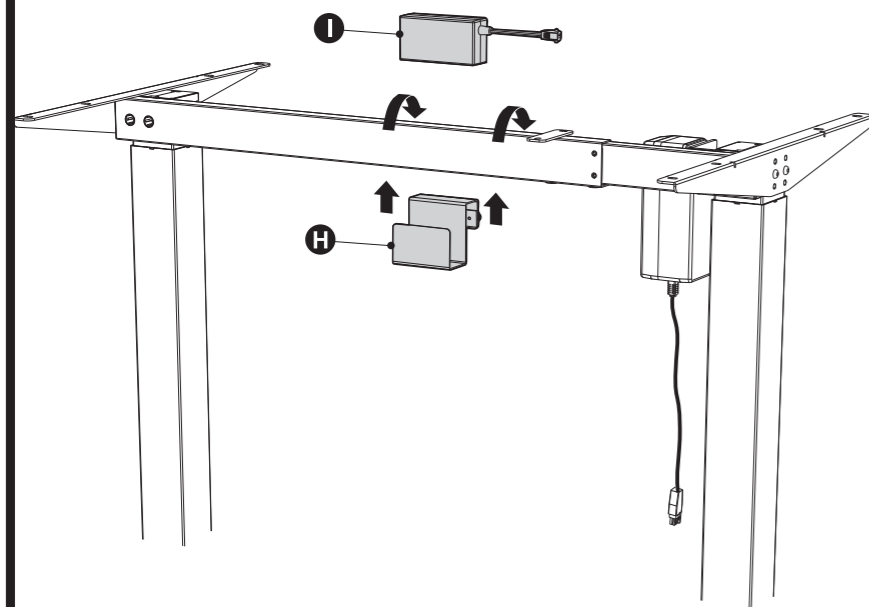

6. Connecting Cords and Attaching the AC Adapter

- Connect the controller **K** with the AC adapter **I** and motor as shown.
 - Insert the power plug **J** into the AC adapter.
- Note:** The picture of the controller is for your reference only. Actual product may vary.

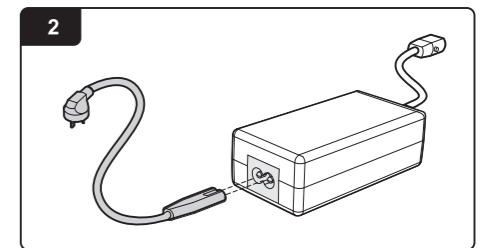
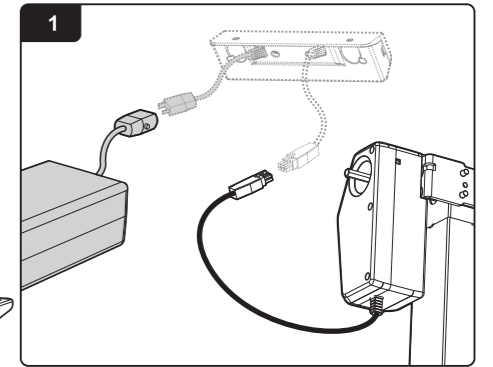
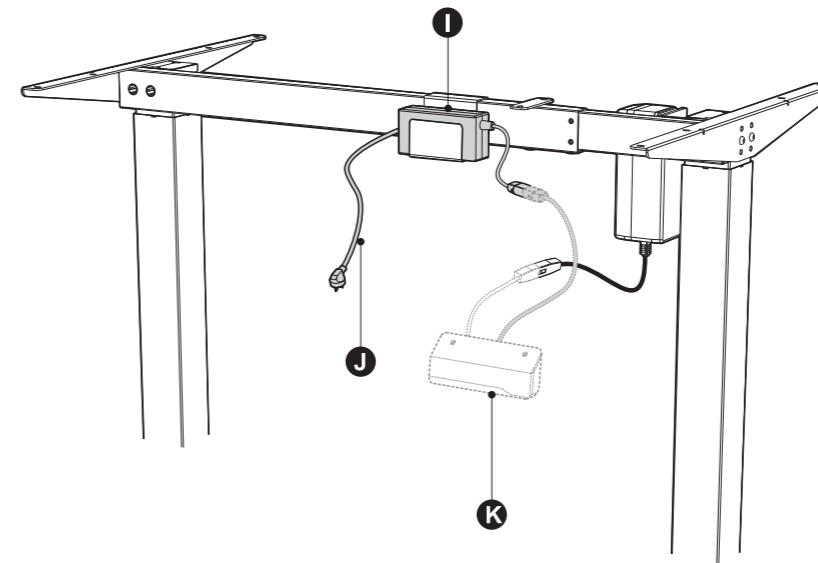

7. Assembling the Desktop

- Attach the anti-vibration pad **S-E** to the surface of the crossbar on the ten positions as shown.

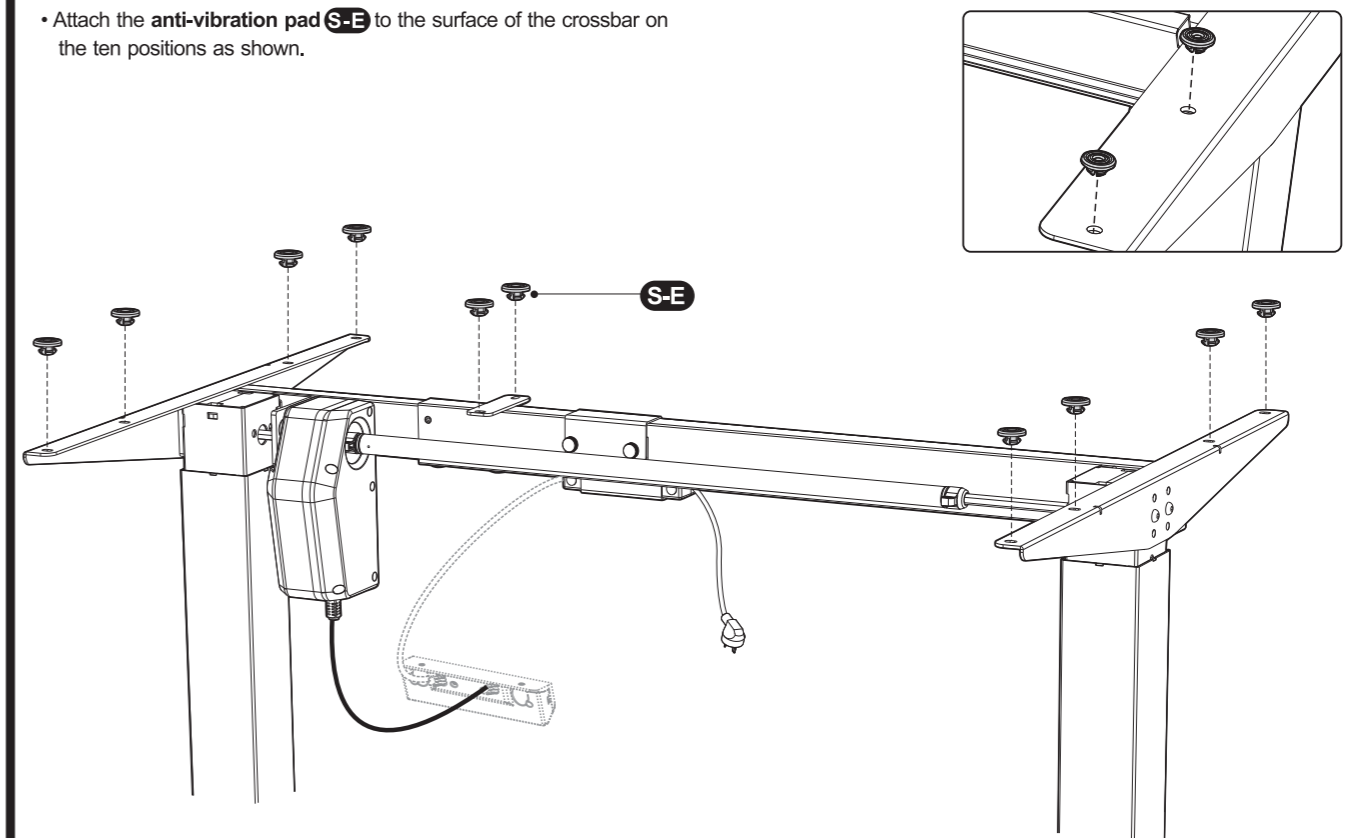

- Turn over the desk frame with the crossbar facing down.
- Align the previously drilled screw holes with the mounting holes on the crossbar. Insert and tighten the **10 screws S-B** from below.

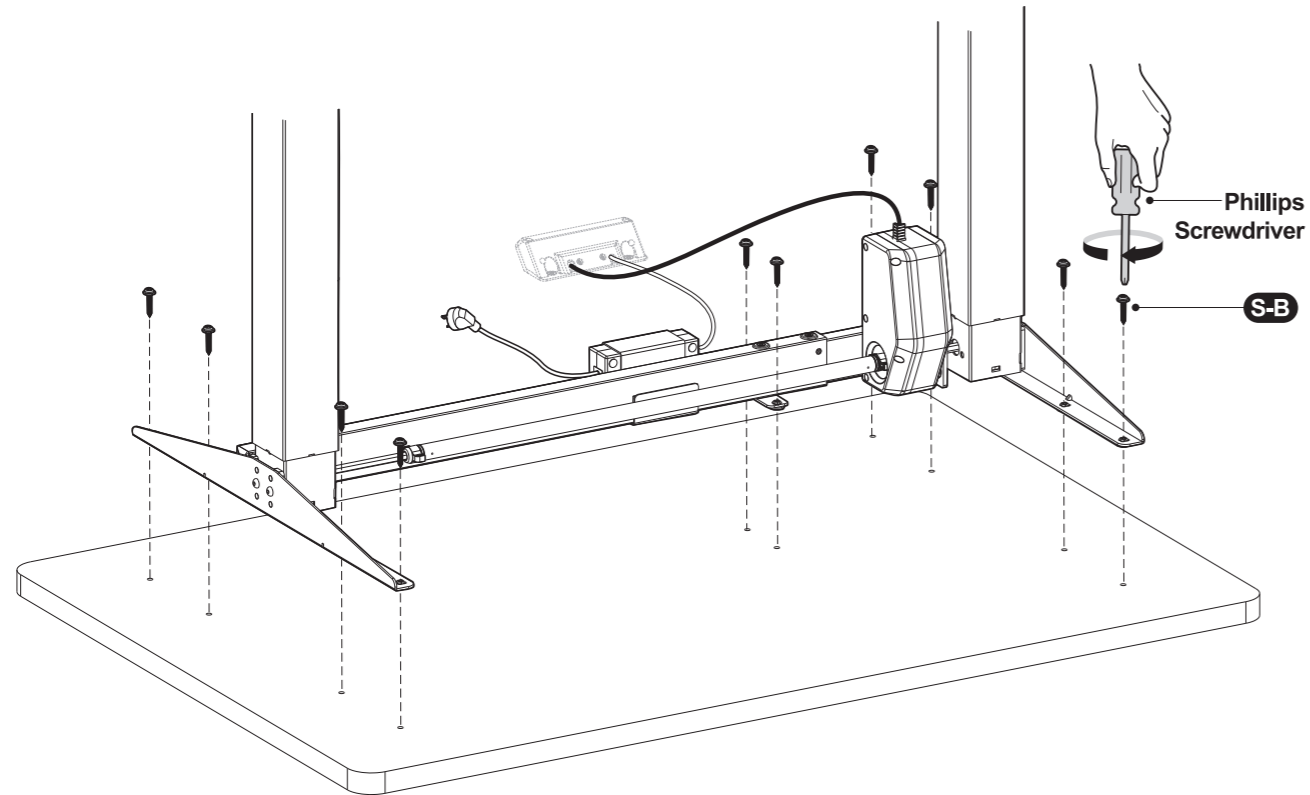

- Attach the controller to the desktop with **2 screws S-C** using a **driller**.
- Stick the adhesive **clip S-D** under desk to organize cords.

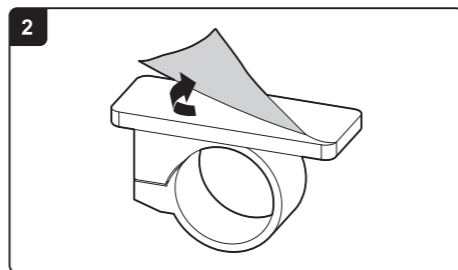
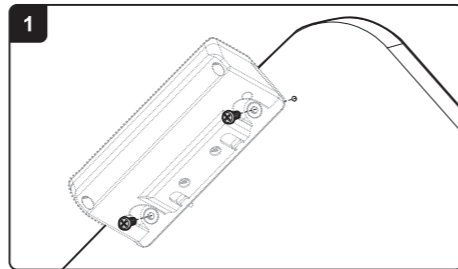
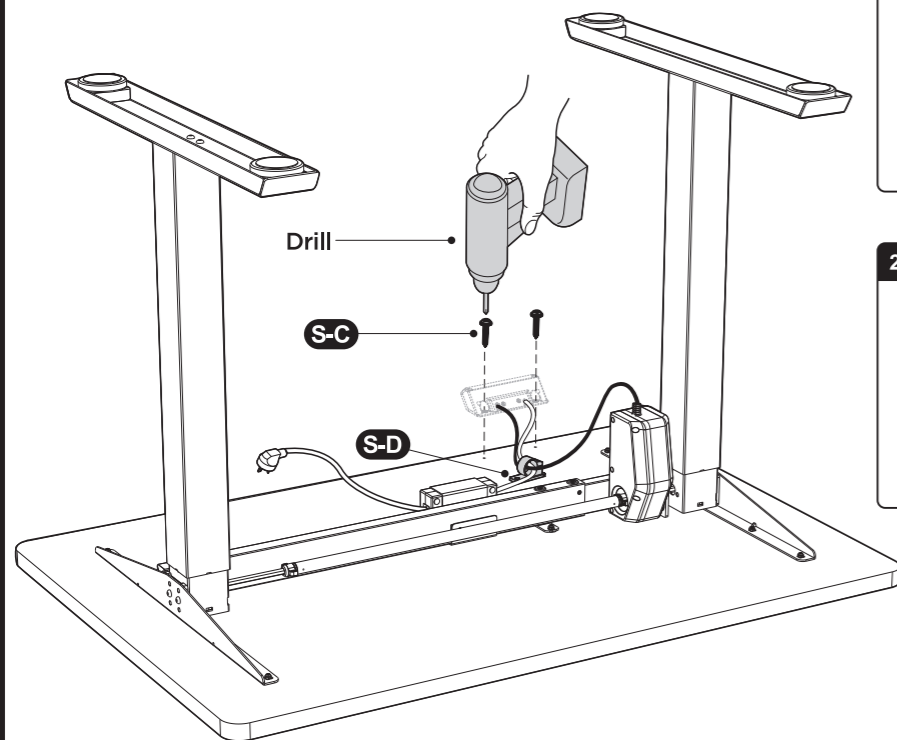

8. Level Adjustment

There are two adjustable foot pads under each foot. If the floor isn't even, simply turn the pad to adjust the height to make the desk stable.

Tip: Use a **bubble level** to check if the desktop is even.

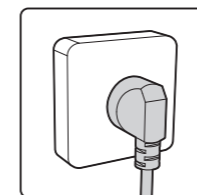
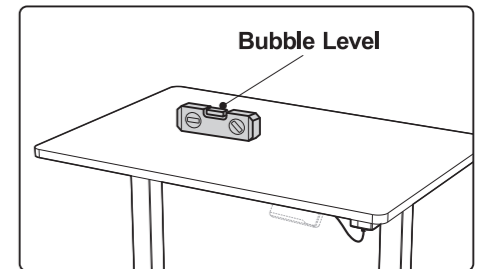
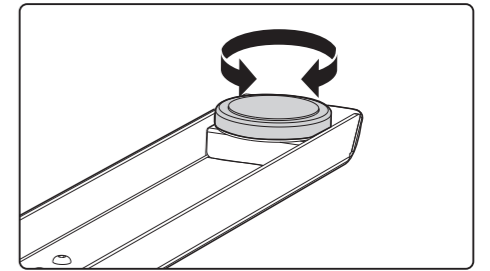
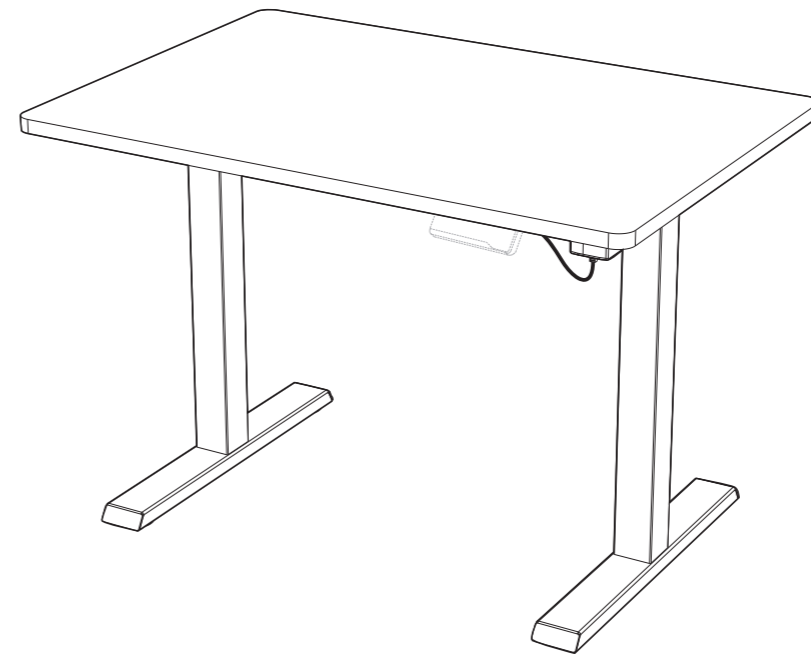

Connect the desk to power.
You can now use the sit-stand desk.

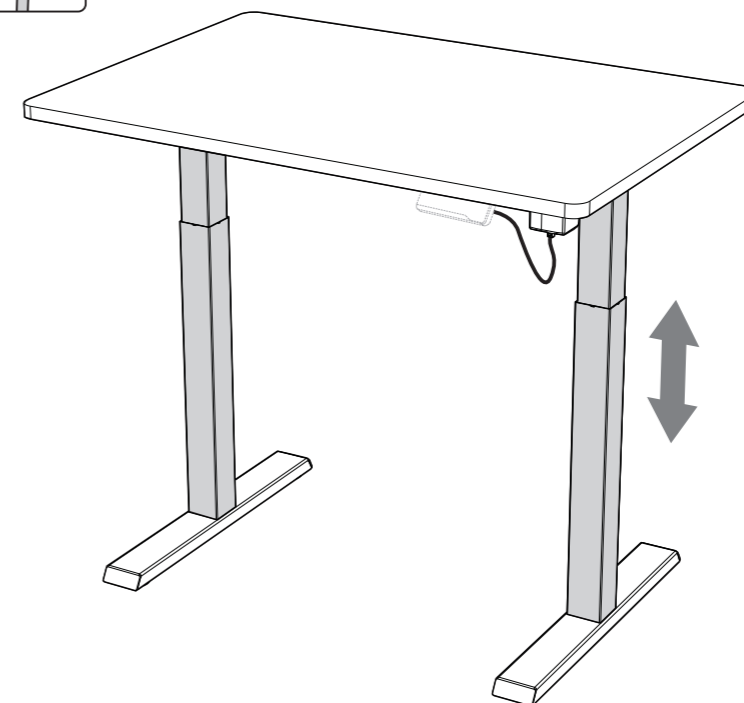

Note: We have another manual of the digital controller for detailed instruction. Please check the Digital Control Panel For Electric Height Adjustable Desk User Guide.